



# Frontrunner Entrance Flooring System

## INSTALLATION INSTRUCTIONS

### RECESSED APPLICATIONS

Please read these instructions carefully and completely before commencing installation.

#### 1 PREPARATION

---

- A It is recommended that the entrance flooring system be installed as one of the final jobs to avoid damage associated with general building works.
- B Un-pack and inspect all materials to ensure they are free from transport damage.
- C Check all components and tools required are available.
- D Unroll/unpack the sections of matting and lay in a clean dry protected area to acclimatise and relax. Depending on duration of storage and ambient temperature, this process may take up to 24 hours. A Heatgun can be used to aid relaxation of matting.
- E When handling the rolls or large panels of matting at any time during the installation, avoid dragging or rough handling that may cause stretching or distortion.

#### 2 EQUIPMENT REQUIRED

---

- Frontrunner entrance flooring matting (supplied).
- Aluminum sections x 5 types (supplied as required).
- 'R' SECTION  
for front to back edges (*in direction of traffic*)
- 'U' SECTION  
for left to right edges  
(*across the direction of traffic*).
- 'H' SECTION  
dividers for large front to back installations and in place of 'U' sections.
- 'T' SECTION  
dividers for large left to right panels.
- 'L' SECTION  
for circular door and non-rectangular installations.

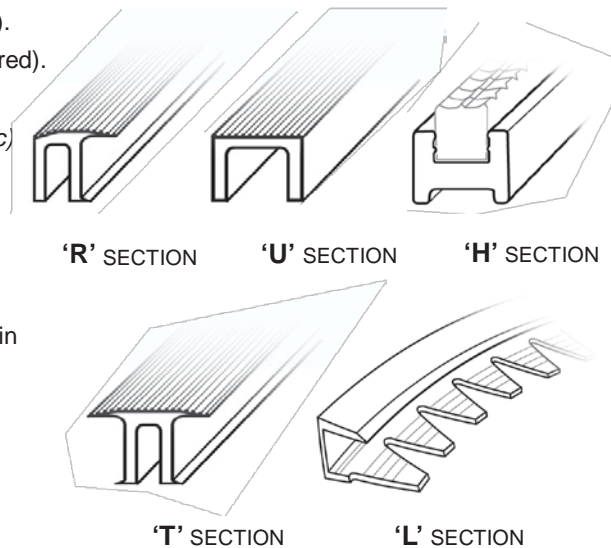

- Screws, rawl plugs & secateurs for trimming mat.
- A powered drill with size 5.5mm masonry drill bit, hacksaw, utility knife and straight edge.
- A hot air gun may facilitate installation in cold ambient temperatures.

### 3 DEFINITIONS (as per British Standard 7953-1999; Selection Installation and Maintenance of Entrance flooring systems)

---

<b>WIDTH</b>	Distance measured at right angles to the direction of traffic flow.
<b>LENGTH</b>	Distance measured in the direction of traffic flow (Note: The length as defined here can, in some instances, be shorter than the width.)
<b>DEPTH</b>	Thickness of the entrance flooring system material.
<b>RECESSED WELL</b>	System specifically constructed to hold the entrance flooring system so that its surface is at the existing floor level.

### 4 THE RECESSED WELL

---

The recessed well should be to a depth of 14mm\* from the finished floor level. It should have a level and sound base, free from any obstructions.

Before commencing installation, visually check the recess and remove any lumps or ridges in the base that may be present. Vacuum and/or sweep recess.

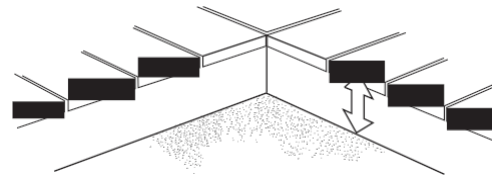

**14mm\* depth**  
(from recessed well base to finished floor surface)

\* 10mm for low profile systems

## 5 INSTALLING THE PERIMETER ALUMINIUM EDGING

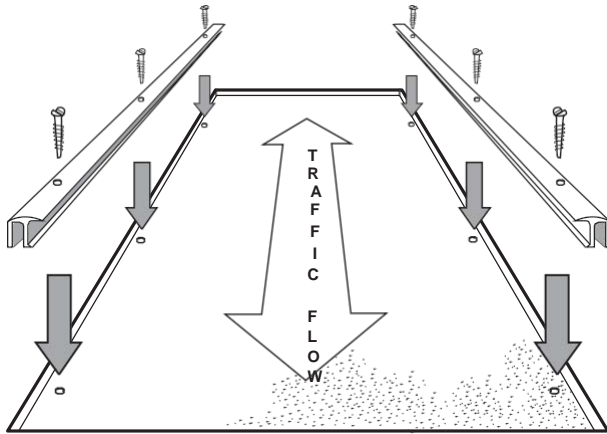

The edging sections will have been supplied oversize and will require final cutting to size on site with a hacksaw.

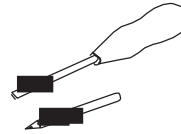

### A *Fitting the 'R' section edging to the left and right hand sides of the recess.*

- 1 'R' sections should be fitted first.
- 2 Ensure the vertical sides of the existing recess are free of protrusions.
- 3 Position each edge sections against the left and right sides of the recess so that lip of the frame protrudes into the recess. When secured the matting will fit under the protruding edge.
- 4 Mark the floor below each counter sunk hole.
- 5 Remove edging and fit rawl plugs.
- 6 Re-position the frames but **do not secure** to floor at this time.

Note: If recessed well edges are already adequately contained with a metal edging section, the 'Inverted U' may not be required.

### B *Fitting the 'inverted U' to the front and back edges of the recess.*

- 1 Mark the floor below each counter sunk hole.
- 2 Remove edging and fit rawl plugs.
- 3 Replace 'Inverted U' frames and semi-tighten down.
- 4 Position the 'R' frames and semi-tighten down.
- 5 Confirm all fit correctly and secure completely.

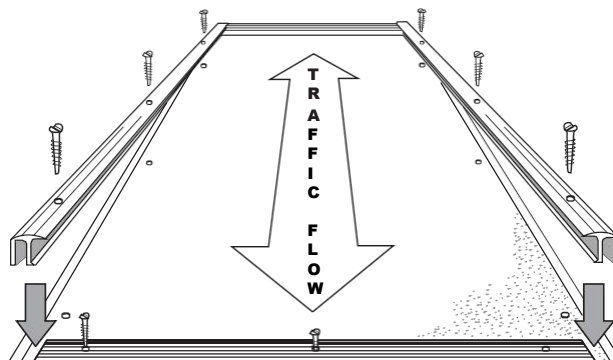
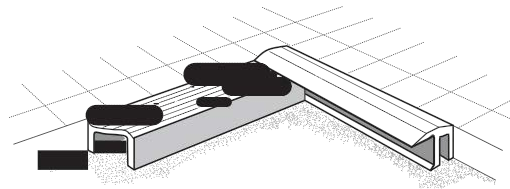

**C Formable Trim**  
(for circular door and other curved applications).

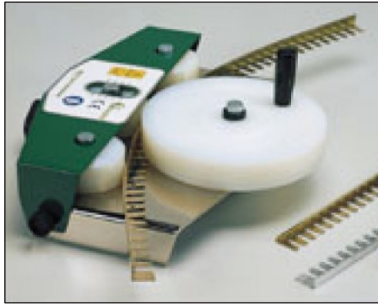

A manually operated machine is required to curve the 'L' section.



In the UK & US a loan machine for one-off installations is available from Plastic Extruders Limited. For overseas installations or to purchase a machine, please contact:

**PROFILPAS**, Via Einstein, 38, 35010 Cadoneghe (PD) Italy  
Tel: 049/700491 - 049/8873898 Fax:049/706692 [www.profilpas.com](http://www.profilpas.com)

## 6 INSTALLING THE MATTING (and sub-dividing aluminum sections if required)

*Please read paragraph 7 'Installing sub-dividing aluminum sections' before fitting matting.*

The sections of matting will have been supplied slightly oversize and may require final trimming on site. Note: When installing Fronrunner Plus or Brush ensure final trim edge retains at least one PVC bar (ie. do not trim so that insert forms edge).

The matting should be laid so that top ribs are across traffic flow with the narrower spaced bars uppermost.

- Cut matting using a utility knife and a straight edge. In cold ambient temperatures warm matting with hot air gun to facilitate cutting.
- Position one end of mat under 'R' frame and lay out mat in recess. Trim other end so that finished section of matting is a loose fit under both protruding lips of 'R' frames (or 'T' frame if applicable) .
- Ensure top surface is uppermost when doing any final trimming.
- Due to the elastic nature of the product, it is important to avoid rough handling of product during installation thus preventing possible stretching.

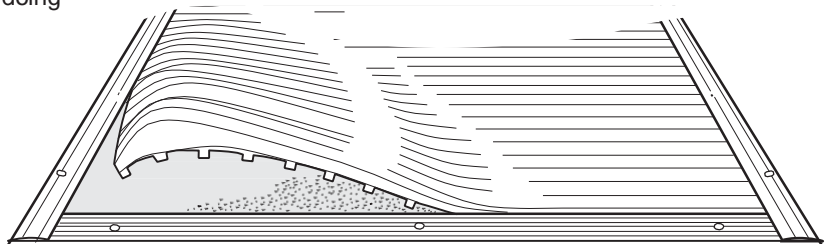

### A Installing multiple widths of matting into matwells

Where the front to back dimension of the mat well is greater than the maximum width of the matting available, it is recommended to cut the matting so that the base bars of one section of the matting extend outwards to form a 'dog leg' spacer (shown in red), resulting in a visually seamless join.

Frontrunner Entrance Flooring cut with a 'dog leg' spacer.

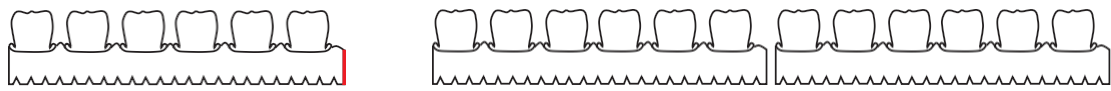

When the next section of Frontrunner Entrance Flooring is positioned against the 'dog leg', the spacing of the top ribs is maintained to provide a seamless join.

↑ 'dog leg seam' prior to butting matting together

This process can be repeated over multiple widths.

## 7 INSTALLING SUB-DIVIDING ALUMINIUM SECTIONS (if applicable)

### A 'T' Frames

For installations over 4m width approx., 'T' frames may be required to separate the matting into manageable sizes.

It is recommended that the 'T' frames, if used, are fitted in line with the door posts spacing, or other area not directly in the main traffic flow.

Position and mark floor below etc. as detailed in paragraph 5.

Do not tighten home screws until all frames and dividers are fitted.

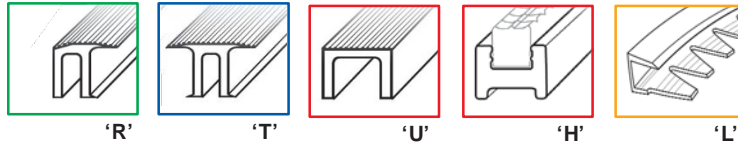
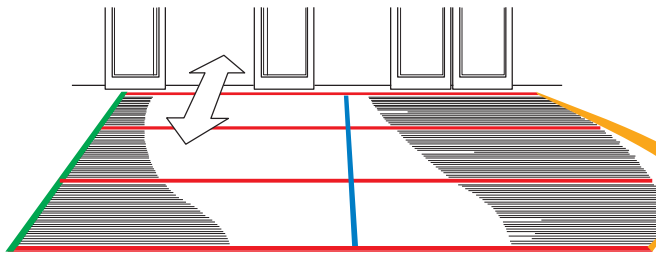

### B 'U' Frames

For installations over 1.8m approx. in length (in direction of traffic), the inverted 'U' frames should be used as spacers to separate the matting into manageable sizes.

Install the sub-dividing 'U' frames along the length of the recess as follows;

- 1 Starting at the threshold edge of the recess, install the first section of matting as detailed in paragraph 6.
- 2 Position divider along exposed edge and mark holes for drilling as detailed in paragraph 5B.
- 3 Repeat process of mat section then inverted 'U' until complete length of well is covered.
- 4 The matting will have been supplied in sizes to provide uniform spaced frame sections.

### C 'H' Frames

For installations over 1.8m approx. in length (in direction of traffic), 'H' frames can be used instead of the 'U' frames described in B above.

- 1 Starting at the threshold edge of the recess, install the first section of matting as detailed in paragraph 6.
- 2 Position 'H' frame, with shorter legs on the floor, along exposed edge. Drill through locator holes and mark subfloor below.
- 3 Remove 'H' frame and drill holes in sub floor with 5,5mm masonry drill and then fit Rawl Plugs.
- 4 Repeat process of mat section the 'H' section until complete length of well is covered.
- 5 Fit PVC section insert so that pattern is uppermost. The PVC section is a friction fit and may need gentle hammering into place. For additional security, superglue can be used to secure the PVC insert to the 'H' section.

Once all frames and mat sections are positioned tighten home all screws on all frames so that entire installation is secured.

Cover and protect entrance matting system until final cleaning prior to opening.

Notes:



*For further information please contact your supplier:*

Manufactured by: **PLASTIC EXTRUDERS LTD**

TEL: (01268) 571116

FAX: (01268) 560027

e-mail: [sales@plastex.co.uk](mailto:sales@plastex.co.uk)

